

- > Port size:  
DN 15 ... DN 50
- > High flow rate
- > Damped operation
- > Functional compact design
- > Solenoid interchangeable without tools (Click-on®)
- > Fluids of Group 2 acc. Pressure Equipment Directive 2014/68/EU
- > International approvals

Click-on®

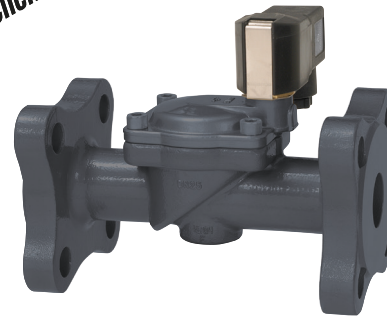

### Technical features

**Medium:**

Neutral gases and liquids

**Switching function:**

Normally closed

**Operation:**

Indirectly solenoid actuated

**Mounting position:**

Optional, preferably solenoid vertical on top

**Flow direction:**

Determined

**Port size:**

 DN 15, DN 20, DN 25,  
DN 32, DN 40, DN 50

**Operating pressure:**

 0,1 ... 10/16 bar  
(1,45 ... 145/232 psi)

**Differential pressure:**

0,1 bar (1,45 psi) required

**Fluid temperature:**

-10 ... +90°C (+14 ... +194°F)

**Ambient temperature:**

-10 ... +50°C (+14 ... +122°F)

**Material:**

Body: Cast steel, Brass

Seat seal: NBR

 Internal parts: Stainless steel,  
PVDF resp. Brass from DN 32

For contaminated fluids insertion of a strainer is recommended.

### Technical data – standard models

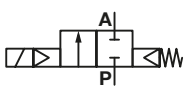
Symbol	Orifice (mm)	Flow kv value *1) (m³/h)	Operating pressure *2) (bar) (psi)		Weight (kg)	Model
	15	3,8	0,1 ... 16	1,45 ... 232	2,6	8303200.9101.xxxxx
	20	6,1	0,1 ... 16	1,45 ... 232	2,8	8303300.9101.xxxxx
	25	9,5	0,1 ... 16	1,45 ... 232	3,2	8303400.9101.xxxxx
	32	23	0,1 ... 10	1,45 ... 145	5,8	8303500.9101.xxxxx
	32	23	0,1 ... 16	1,45 ... 232	5,9	8303500.9151.xxxxx
	40	25	0,1 ... 10	1,45 ... 145	6,1	8303600.9101.xxxxx
	40	25	0,1 ... 16	1,45 ... 232	6,2	8303600.9151.xxxxx
	50	41	0,1 ... 10	1,45 ... 145	8,4	8303700.9101.xxxxx
	50	41	0,1 ... 16	1,45 ... 232	8,5	8303700.9151.xxxxx

xxxxx Please insert voltage and frequency codes

\*1) Cv-value (US) ≈ kv value x 1,2

\*2) For gases and liquid fluids up to 25 mm²/s (cSt)

Option selector

8303\*\*\*\*\*.\*\*\*\*\*

Port size	Substitute
15	2
20	3
25	4
32	5
40	6
50	7
Valve options	Substitute
Normally open (NO), Operating pressure 0,1 ... 16 bar (1,45 ... 232 psi) from DN 32 only with solenoid 9151	01
Manual override	02
Seat seal FPM, Fluid temperature -5 ... +110°C (+23 ... +230°F)	03
Seat seal EPDM, for hot water, Fluid temperature -10 ... +110°C (+14 ... +230°F) Operating pressure: up to DN 25: 0,3 ... 16 bar (4,35 ... 232 psi) from DN 32: 0,3 ... 10 bar (4,35 ... 145 psi)	14
Flanges acc.to ASME B 16.5 150 lb/sq.in.	47

Frequency	Substitute
See table frequency codes	xx
Voltage	Substitute
See Voltage codes	xxx
Solenoid options	Substitute
up to DN 25 Operating pressure 0,1 ... 16 bar (1,45 ... 232 psi) from DN 32 Operating pressure 0,1 ... 10 bar (1,45 ... 50 psi)	9101
Operating pressure 0,1 ... 16 bar (1,45 ... 232 psi)	9151

**Acc. to ATEX 2014/34/EU**
**Actuation solenoids – Technical data and connection type**

Solenoid	Code Voltage	Code Frequency	Voltage	Frequency	Power consumption		Connection
					Inrush	Holding	
3826	024	00	24 V DC	-	13,6 VA	13,6 VA	1/2" Conduit 3 connection strands, length 460 mm cable gland 1/2-14 NPT
3827	230	49	230 V AC	40 ... 60 Hz	15,4 VA	15,4 VA	1/2" Conduit 3 connection strands, length 460 mm cable gland 1/2-14 NPT
4280	024	00	24 V DC	-	11,4 W	11,4 W	cable gland M20 x 1,5 Note: A cable gland made from plastic must be chosen during order.
4281	230	49	230 V AC	40 ... 60 Hz	15,2 VA	15,2 VA	cable gland M20 x 1,5 Note: A cable gland made from plastic must be chosen during order.
4680	024	00	24 V DC	-	11,4 W	11,4 W	connection housing for cables 7,5-11,9 mm cable gland 1/2-14 NPT
4681	230	49	230 V AC	40 ... 60 Hz	15,2 VA	15,2 VA	connection housing for cables 7,5-11,9 mm cable gland 1/2-14 NPT
4682	024	00	24 V DC	-	11,4 W	11,4 W	connection housing for cables 10-14 mm cable gland M20 x 1,5
4683	230	49	230 V AC	40 ... 60 Hz	15,2 VA	15,2 VA	connection housing for cables 10-14 mm cable gland M20 x 1,5
6126	024	00	24 V DC	-	14 W	14 W	connection housing for cables 7-9 mm cable gland M16 x 1,5
6126	230	49	230 V AC	40 ... 60 Hz	16 VA	16 VA	connection housing for cables 7-9 mm cable gland M16 x 1,5
9841	024	00	24 V DC	-	10,1 W	10,1 W	with 3 m connection cable
9844	024	00	24 V DC	-	10,1 W	10,1 W	with 5 m connection cable
9845	024	00	24 V DC	-	10,1 W	10,1 W	with 10 m connection cable
9845	230	59	230 V AC	50 ... 60 Hz	9,2 VA	9,2 VA	with 10 m connection cable

**Electrical details for all solenoid systems**

<b>Voltage range</b>	±10%
<b>Duty cycle</b>	100% ED
<b>Protection class</b>	EN 60529 IP65 (exception 428x: IP66)

According to DIN VDE 0580 at a solenoid temperature of +20°C.  
At operating state temperature the input power of a coil decreases by up to ca. 30% due to physical reasons..

**Additional solenoid systems for hazardous areas**

Solenoid	ATEX category	Ex-protection class
428x	II2G II2D	Ex eb mb IIC T4/T5 Gb Ex tb IIIC T 130 °C D IP66
468x	II2G II2D	Ex d mb IIC T4/T5 Gb Ex tb IIIC T130°C/T95°C Db
984x	II2G II2D	Ex mb IIC T4 Gb Ex mb tb IIIC T130°C Db
6126	II 2G II 2D	Ex eb mb IIC T4 Gb Ex mb tb IIIB T125°C Db IP66

**Solenoid systems with FM approval (USA)**

Solenoid	FM approval
382x	1,3,4,4X,6,6P,7 und 9 FM approved (File Nr. 2Z2A6.AE)

**Admissible Ex areas (USA)**

Solenoid 382x	Class	Divison	Groups
Gases + fumes	I	1 and 2	A ... D
Dusts	II	1 and 2	E ... G
Fibres + fluffs	III	1 and 2	–

**Section View  
up to DN 25**

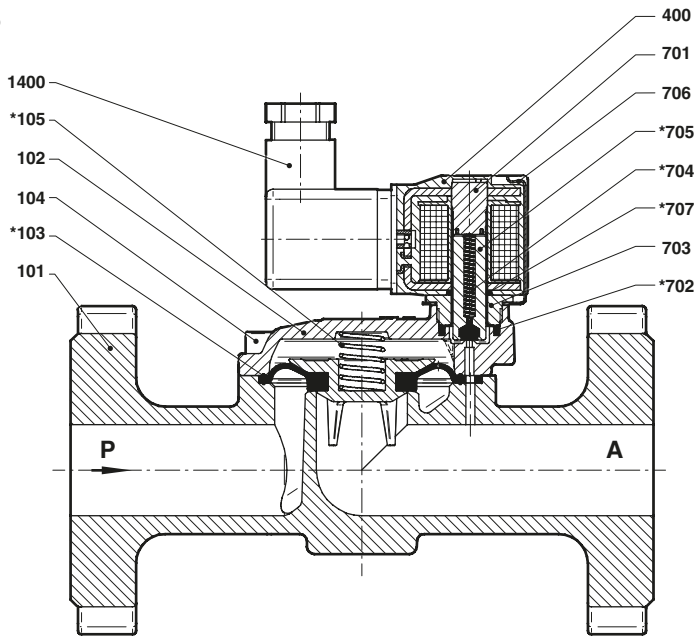

No.	Description
101	Valve body
102	Valve cover
*103	Diaphragm
104	Straight pin
*105	Pressure spring
400	Solenoid
701	Core tube
*702	O-ring
703	Screw piece
*704	Pressure spring
*705	Core
706	Spring clip
*707	O-ring
1400	Socket (included)

**from DN 32**

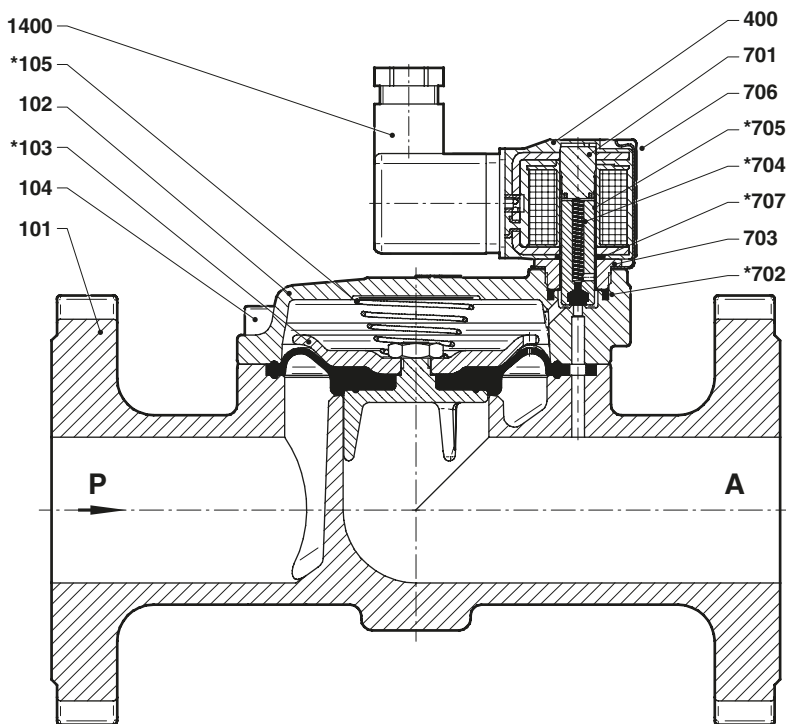

No.	Description
101	Valve body
102	Valve cover
*103	Diaphragm
104	Straight pin
*105	Pressure spring
400	Solenoid
701	Core tube
*702	O-ring
703	Screw piece
*704	Pressure spring
*705	Core
706	Spring clip
*707	O-ring
1400	Socket (included)

\* These individual parts form a complete wearing unit.  
When ordering spare parts please state Model No. and Series No.

**Dimensions  
DN 15 ... 50**

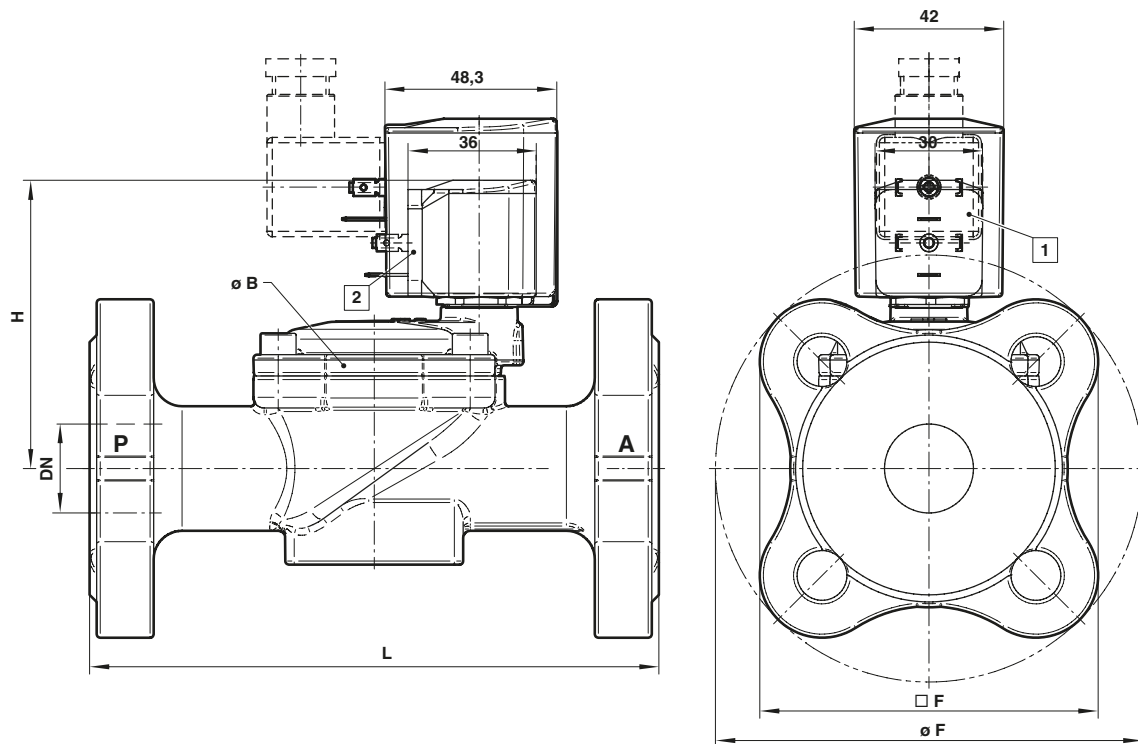
 Dimensions in mm  
 Projection/First angle

- 1 Solenoid rotatable 360°
- 2 Socket turnable 4 x 90°  
(Socket included)

Orifice (mm)	ø B	ø F	F	H	L	Model
15	44	96	77	69	130	8303200.9101.xxxxx
20	50	110	86,6	77	150	8303300.9101.xxxxx
25	62	120	95,1	81	160	8303400.9101.xxxxx
32	92	140	110,7	97	180	8303500.9101.xxxxx
32	92	140	110,7	114	180	8303500.9151.xxxxx
40	92	150	117,8	102	200	8303600.9101.xxxxx
40	92	150	117,8	119	200	8303600.9151.xxxxx
50	109	165	128,4	113	230	8303700.9101.xxxxx
50	109	165	128,4	131	230	8303700.9151.xxxxx

Contact face acc. to DIN EN 1092-1/B

**Note to Pressure Equipment Directive (PED):**

The valves of this series up to and including DN 25 (G1) are according to Art. 4 § 3 of the Pressure Equipment Directive (PED) 2014/68/EU. This means interpretation and production are in accordance to engineers practice wellknown in the member countries. The CE-sign at the valve does not refer to the PED. Thus the declaration of conformity is not longer applicable for this directive.

**For valves > DN 25 (G1) Art. 4 § (1) Letter d) applies:**

The basic requirements of the Enclosure I of the PED must be fulfilled. The CE-sign at the valve includes the PED. A certificate of conformity of this directive will be available on request.

**Note to Electromagnetic Compatibility Guideline (EEC):**

The valves shall be provided with an electrical circuit which ensures the limits of the harmonised standards EN 61000-6-3 and EN 61000-6-1 are observed, and hence the requirements of the Electromagnetic Compatibility Guideline (2014/30/EU) satisfied.

**Note to EAC marking:**

The EAC-marked products comply with the applicable requirements stated in the technical regulations of the Eurasian Economic Union.